

Parts Included

Frame x1
Legs x2
Nuts x2

Step 1

Place the Frame upside down on a soft surface so that the 2 Threaded Studs are facing up. Align Legs to Threaded Studs and secure with the Nuts provided.

NOTE: The long half of the Leg faces forward.

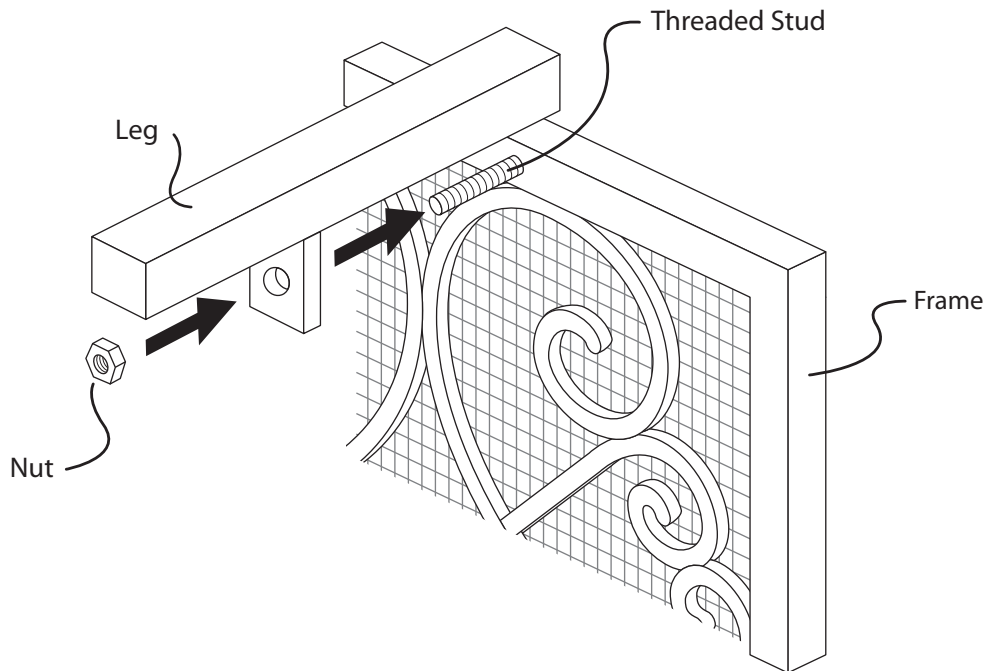

BACK OF SCREEN FRAME SHOWN IN ILLUSTRATION

PART# 18321