

PLEASE READ FIRST BEFORE UNBOXING

* ASSEMBLY INSTRUCTIONS MUST BE FOLLOWED IN THE ORDER BELOW!
PLEASE READ EACH STEP THOROUGHLY BEFORE CONTINUING TO THE NEXT.
READ SAFETY GUIDELINES THOROUGHLY BEFORE USING!



NAPA FIRE PIT ASSEMBLY INSTRUCTIONS*

Parts list

- 1. 1 Fire Pit frame
- 2. 1 Fire Pit pan
- 3. 1 Fire Pit grate
- 4. 1 Mesh ember cover
- 5. 1 Fire tender / Mesh ember lifter
- 6. 1 Mesh ember cover Handle
- 7. 2 Allen head screws
- 8. 1 Allen wrench
- 9. 1 Cover

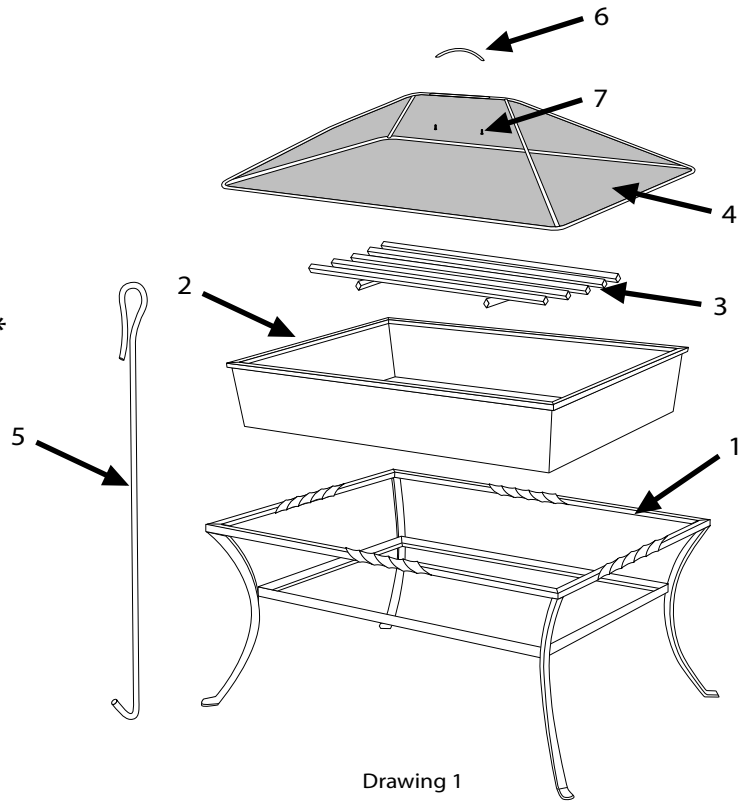

Drawing 1

Instructions

1. Using two people take the Fire Pit frame out of the cardboard box and set to the side.
DO NOT CUT THE PLASTIC STRAPPING!
2. Remove Mesh ember cover from the bottom of the cardboard box.
3. **WEARING EYE PROTECTION**, cut the plastic strapping while placing a firm grip on the Fire Pit grate. The Fire Pit grate is wrapped in cardboard and attached by the plastic strapping located beneath the fire pit frame.
4. Using the Allen wrench supplied attach the Mesh ember cover Handle using the two Allen head screws. (refer to Drawing 2)
5. Refer to Drawing 1 for order of assembly.

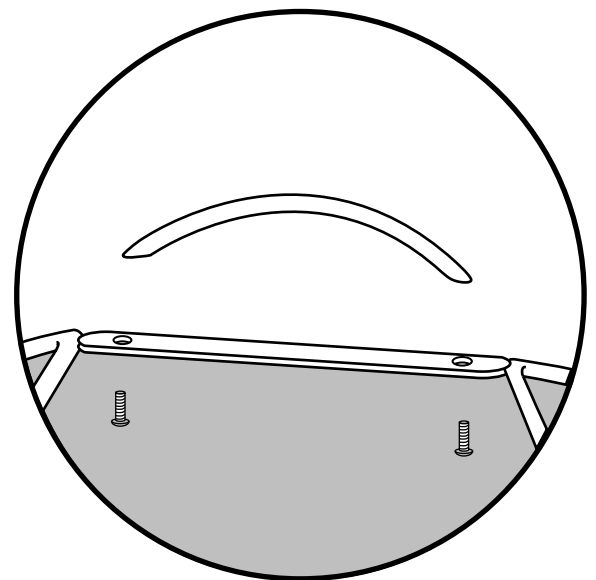

Drawing 2